

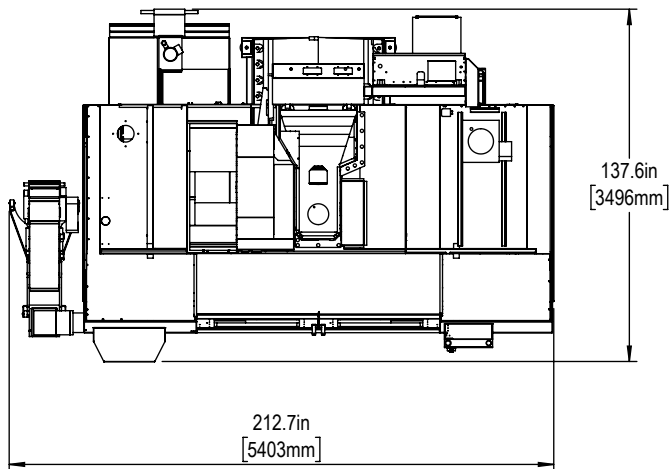

Installed Dimensions

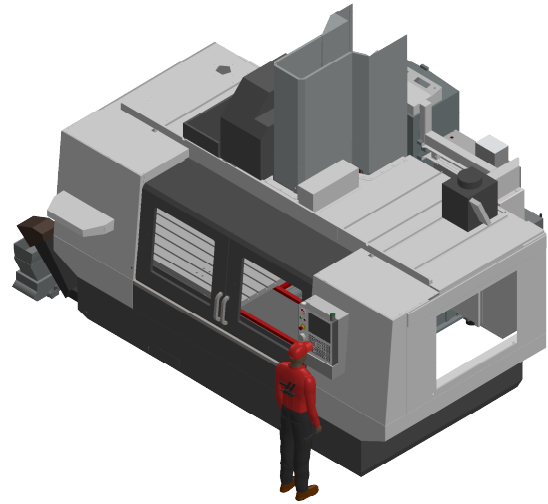
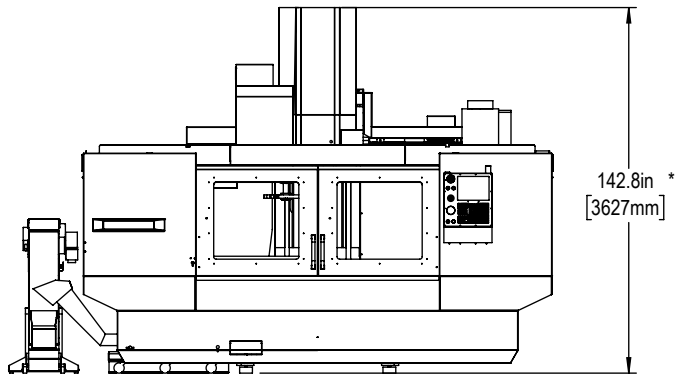

NOTE: 8" EXTENDED Z-AXIS CLEARANCE OPTION  
ADDS 8" (203mm) TO DIMENSIONS WITH \*

Leveling Pad Height

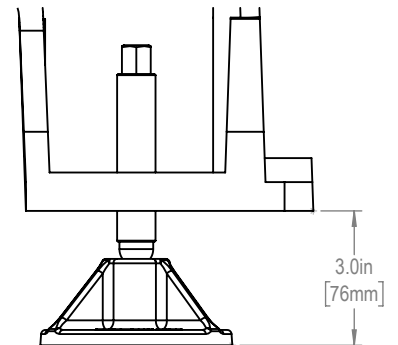

\*All Height Dimensions Based on Suggested Leveling Pad Height

Shipping Dimensions

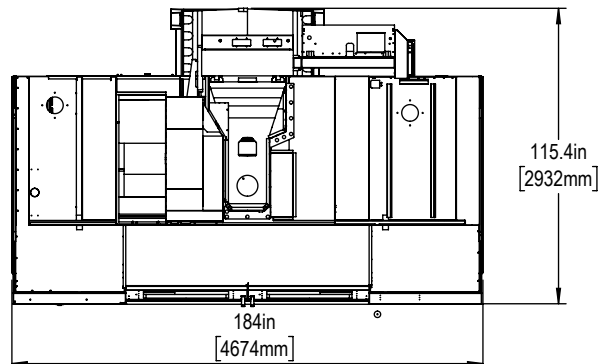
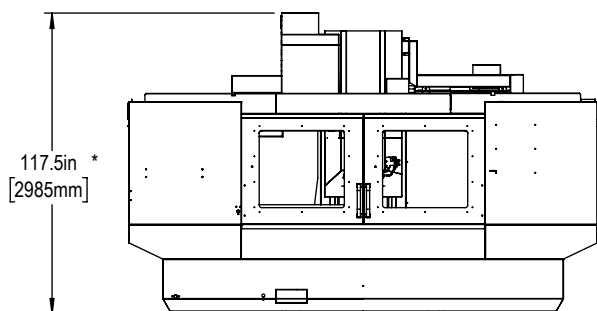

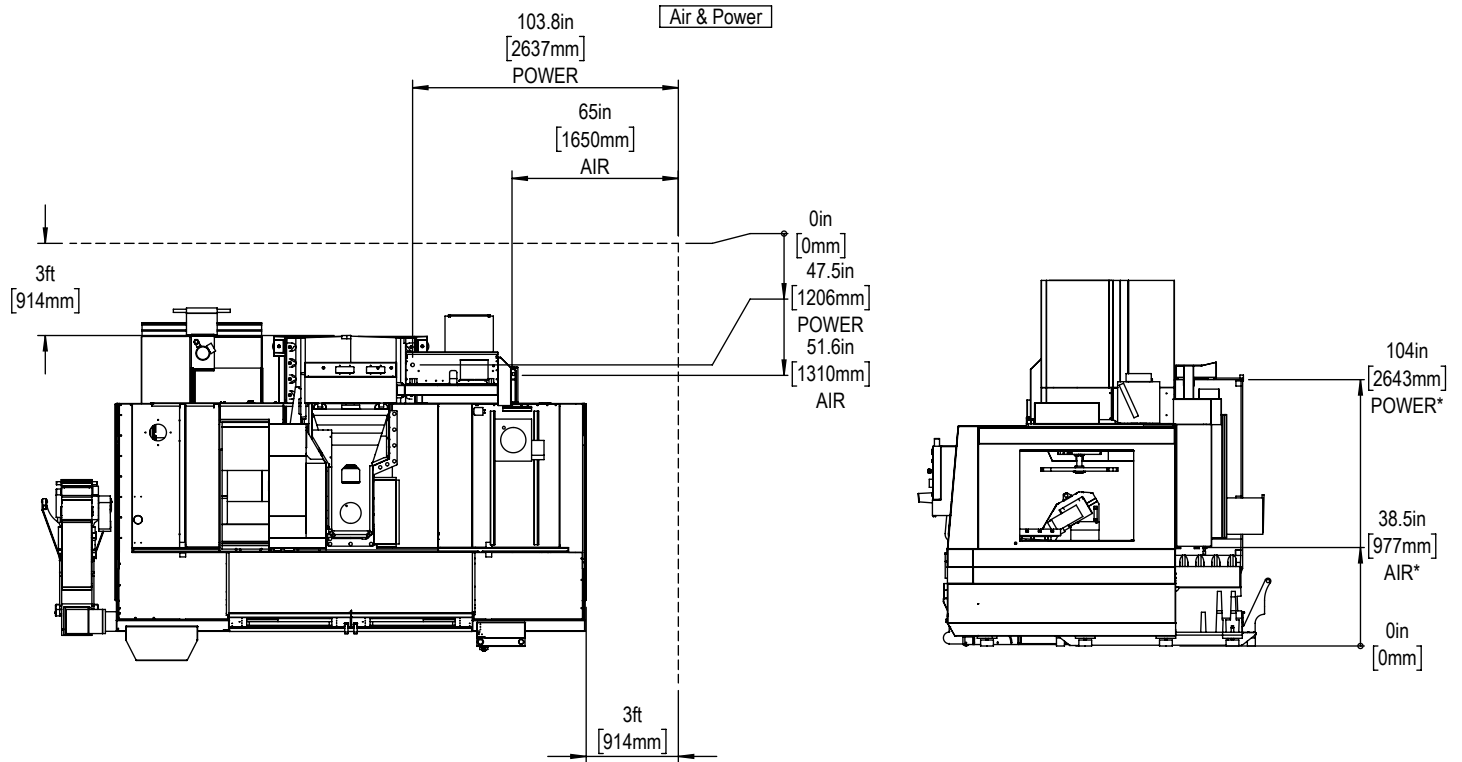

Maintain 3 feet [915mm] clearance to the nearest obstruction around all sides of machine perimeter for maintenance access

**Note:**  
Machine must be placed on one continous concrete slab. Slab should extend 12in [305mm] beyond anchor holes in all directions

**Anchor Pattern**

**Anchor Hole Detail**  
 Ø 1.0in[25mm]  
 ▽ 2.0in[51mm]-  
 ▽ 2.5in[64mm]

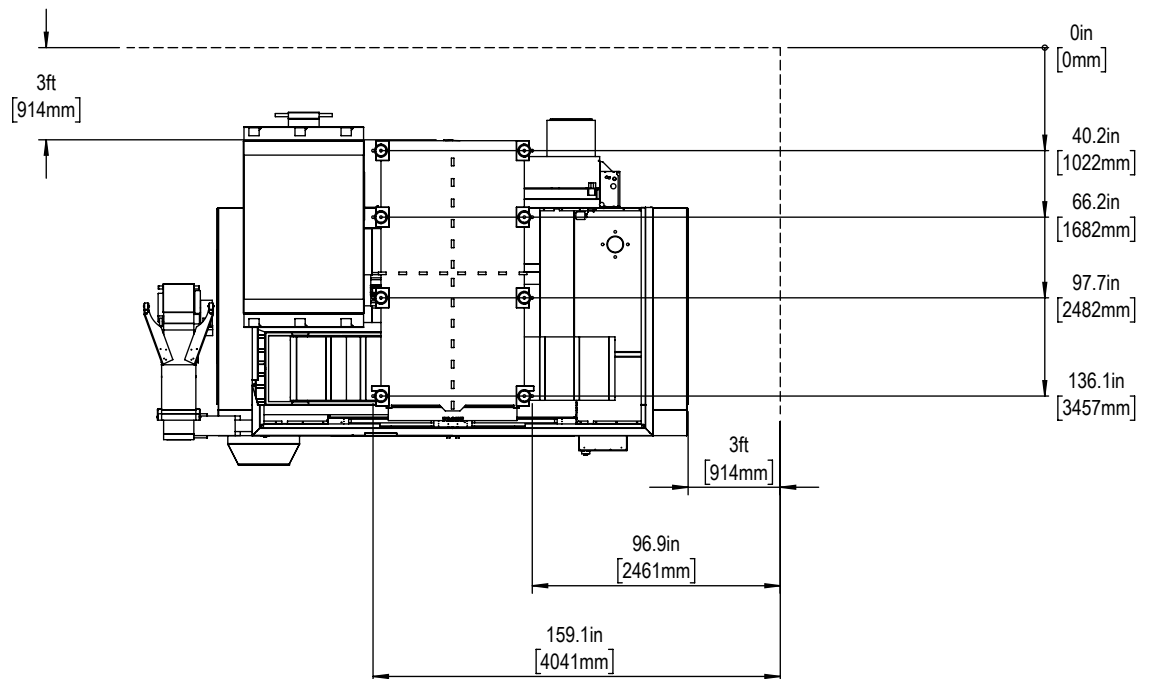

For precise locations and specifications please use template in Anchoring Kit found at Haascnc.com



Height Breakdown

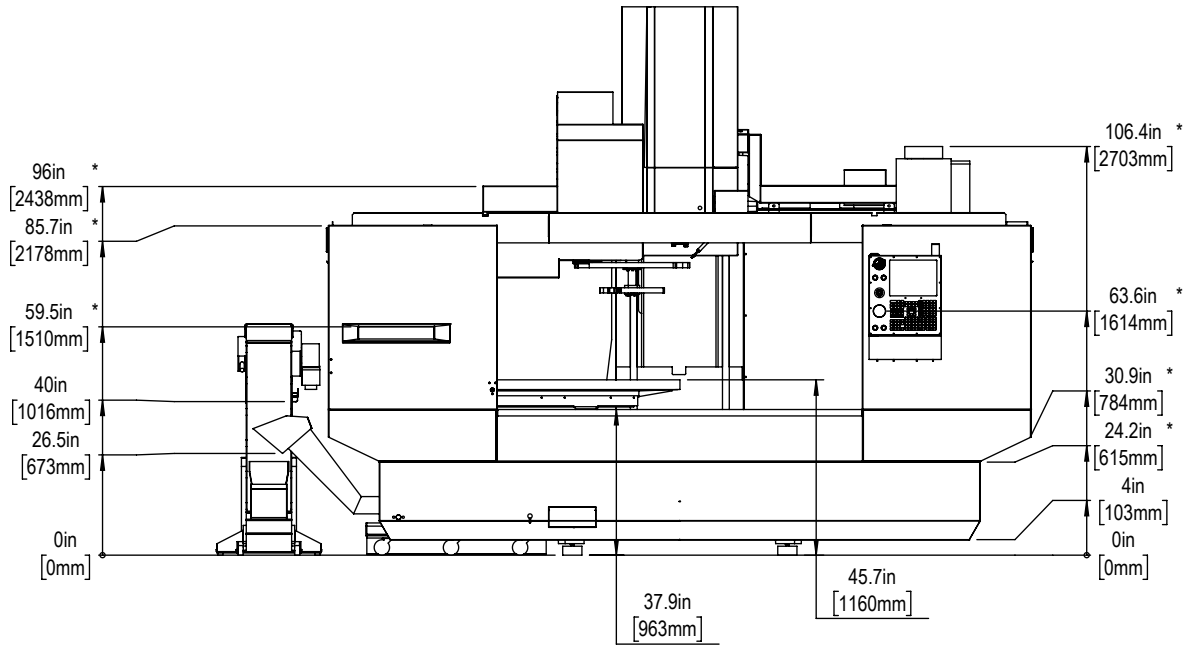

Width Breakdown

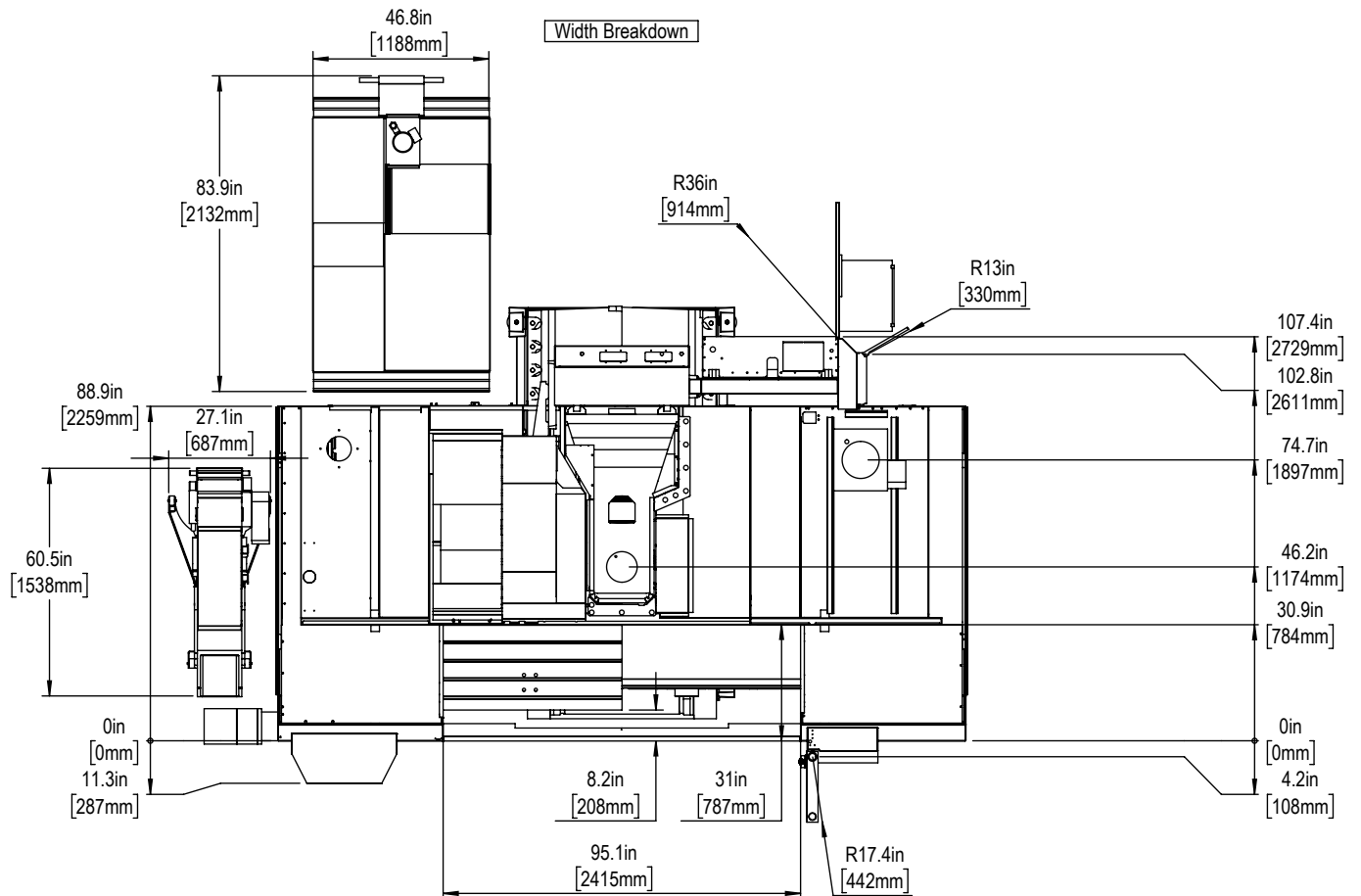

X&Y-Axis Travel and Clearance

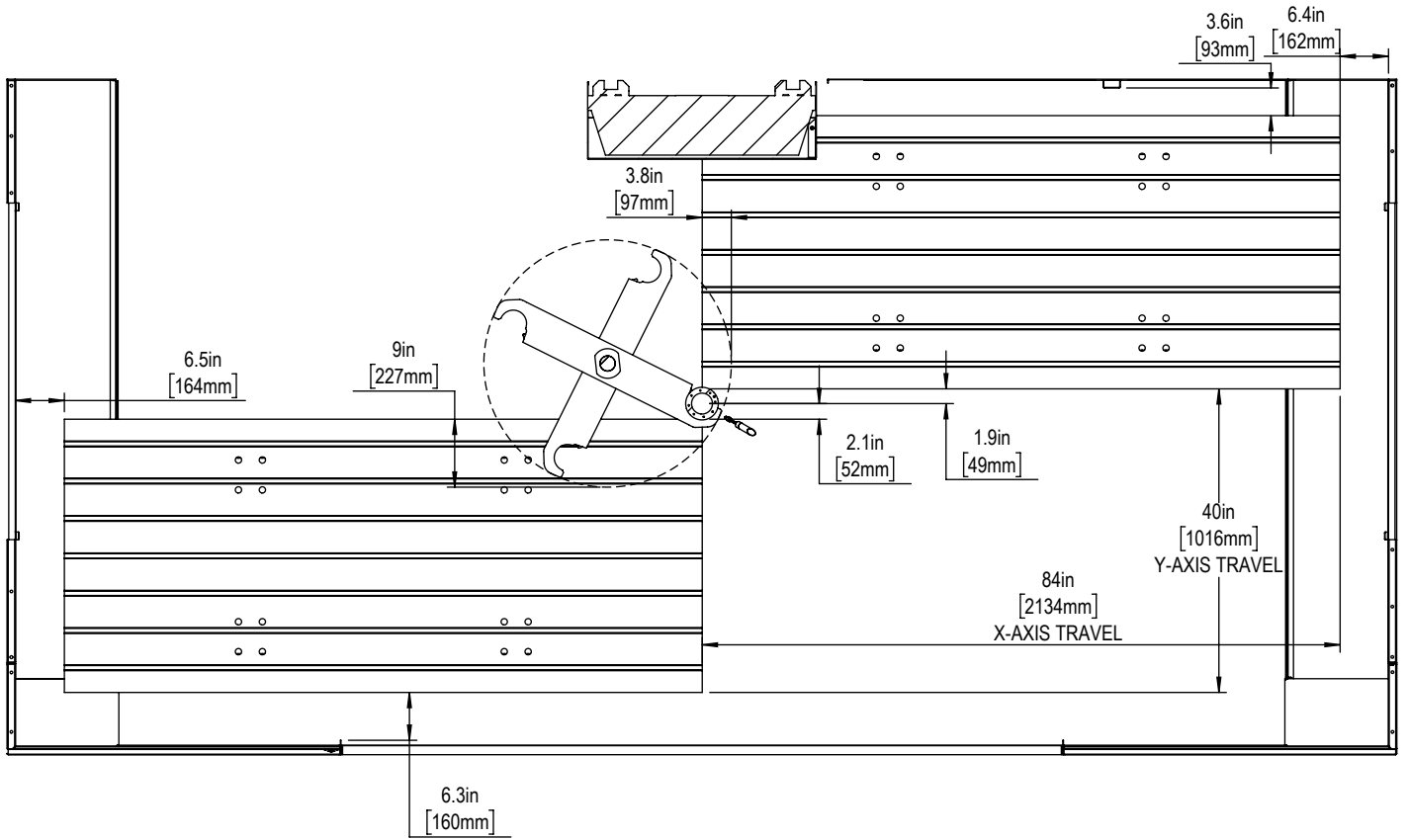

Z-AXIS TRAVEL & CLEARANCE

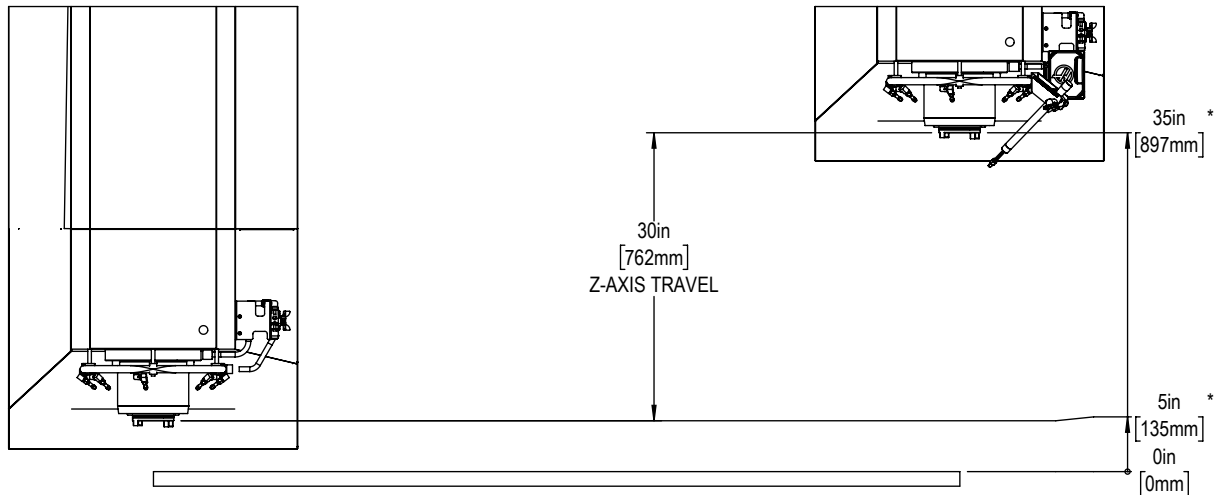
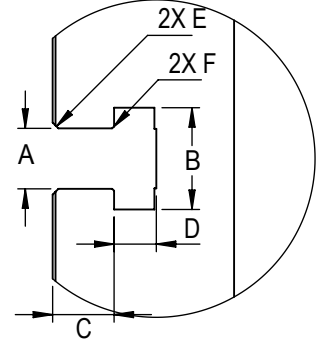



Table  
84in  
[2134mm]



16mm T-SLOTS



T-Slot Dimensions in inches

Slot Size	A	B	C	D	E	F
12mm	$0.438^{+0.002}_{-0.000}$	$0.76 \pm 0.02$	$0.310 \pm 0.010$	$0.318 \pm 0.010$	$0.03 \times 45^\circ$	$0.020 \times 45^\circ$
16mm	$0.628 \pm 0.002$	$1.06 \pm 0.02$	$0.640 \pm 0.010$	$0.420 \pm 0.010$	$0.06 \times 45^\circ$	$0.020 \times 45^\circ$

Tool Changer

